

INSTRUCTIONS FOR THE USE OF THE

HP COMBI PLAN "T"

DAYLIGHT TYPE PROCESSING TANK

**THE
SIMPLEST AND EASIEST
METHOD OF ENSURING
PERFECTLY PROCESSED
SHEET FILM
OR
GLASS PLATES
WITHOUT
STREAKING
AIR BELLS
OR BROMIDE DRAG**



The **HP COMBI PLAN "T"** is a conveniently small tank for processing up to six sheet films or glass plates, black and white or color. It is designed for the utmost economy as the quantity of solution required is very small. It features a sturdy, removable, easily adjusted film carrier for the following formats:

4 x 5" 9 x 12cm 10 x 15cm 10 x 10cm

3 1/2 x 4 3/4" 3 1/4 x 4 1/4" 2 1/2 x 3 1/2" 6.5 x 9cm

The **HP COMBI PLAN "T"** is a daylight type developing tank: After loading the film in a darkroom or changing bag all other operations are carried out in full daylight.

The **HP COMBI PLAN "T"** is of modular design, every component is available individually for replacement. All parts are numbered for quick and easy identification.

The **HP COMBI PLAN "T"** is completely inert to all photographic chemicals.



Marketing Corp 16 CHAPIN ROAD • PINE BROOK, NEW JERSEY 07058 • (201) 808-9010 • FAX (201) 808-9004

DESCRIPTION OF THE HP COMBIPLAN "T"

The **HP COMBI PLAN "T"** is manufactured from the highest quality plastic which, even after prolonged use, is highly resistant to corrosion from all known photographic chemicals, especially the current color developers. In addition, the plastic is an efficient insulator which helps to maintain a consistent temperature during processing.

The **HP COMBI PLAN "T"** consists of the following parts:

1. Lid No. 459409

made from an extra strong, flexible plastic material. This ensures that the lid fits securely on the 459407 tank body and makes inversion agitation possible — the best developing method known. The opening in the lid for filling and draining is provided with a ventilation slot and can be fitted with a light-tight screw-in nipple 459421, which accepts the funnel 459425 or the leak proof cap 459422.



2. Tank Body 459407 (Daylight Type) accommodates film carrier 459812

Its well designed shape enables the user to easily and firmly grip the tank with one hand. The raised, vertical grooves in the front and back of the tank help to prevent slipping — even with wet hands! An outlet is provided on the bottom of one of the small sides to accept either the light tight screw-in hose connector 459421 or the screw-in stopper 459418.

3. Negative Carrier 459812

for up to 6 sheet films or glass plates. The negative carrier consists of the following parts:

A. Two grooved side plates 459412

of clear plastic. On one side the grooves are straight for use with glass plates, the other side is curved for use with sheet films.

B. Upper spacer rod 459413

with format markings and handle. The holes in the handle allow the negative carrier to be easily hung for drying.

C. Lower spacer rod 459414

with raised film separators on the bottom plate.

D. Two locking rings 459415

to fasten the upper and lower spacer rods to the grooved side plates.

E. Film loading guide 459417

to facilitate the loading of sheet film into the negative carrier in the dark. Not used with glass plates.

F. Slip-on ratcheting film retaining clip 459418

slips on to the handle of the negative carrier to hold the film in place, properly separated and keeps film from slipping out of the carrier during inversion agitation.

IMPORTANT: PLEASE SEE LAST PAGE FOR DETAILS.

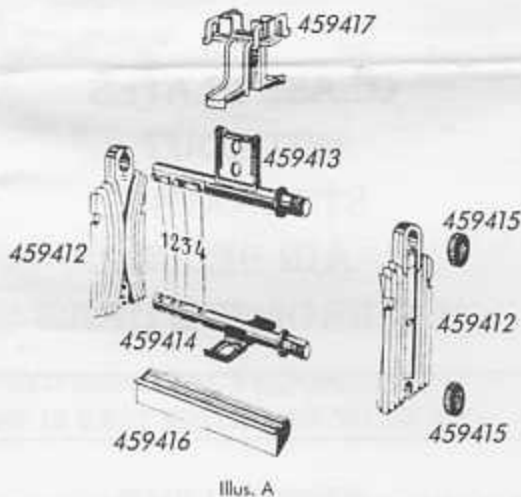

4. Two light-tight screw-in hose connectors 459421

one each for the lid and the tank body openings.

5. Two stopper caps 459422

to make the screw-in hose connectors leak-proof.



459418



459425



459421



459422

6. Funnel 459425

fits in to the light-tight hose connector on lid for filling the tank with chemistry or water.

HP COMBI PLAN "T" ACCESSORY:

1. Screw-in stopper 459418

with rubber washer — used instead of the light-tight screw-in hose connector 459421.

HOW TO USE THE HP COMBIPLAN "T" TANK

A. Assembly of the negative carrier.

It is important to make sure the negative carrier is properly assembled for the type of material that is to be used. For sheet films the curved grooves of the film retaining plates must face each other and the straight grooves must be on the outside side of the film retaining plate. When developing glass plates the film retaining plates must be reversed with the straight grooves facing each other (illus. A). Curved grooves are used for sheet films to impart greater strength so they can resist the pressure of the solutions during inverse agitation. The two spacer rods, 459413 and 459414, have a bayonet type lock to permit adjustment for various film formats and a thread on the opposite end that accepts the locking screw rings 459415. The bayonet cut-outs are numbered to indicate the format positions.

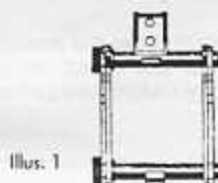

illus. 1

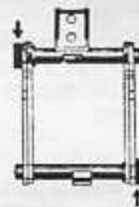

illus. 2

When assembling the negative carrier the upper rod is inserted into the upper opening of the grooved plate with its groove facing down so that the notch in the opening fits smoothly into the groove. As soon as the figure indicating the correct format is over the notch and the latter is in the groove, turn the rod clockwise until it stops (illus. 3). The lower rod is similarly inserted, the only difference is that the



illus. 3

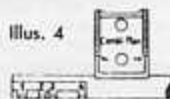

illus. 4

notch and groove should face up. The second grooved plate is now slipped over the rod's screw thread. The notches in the openings of the plates rest on the flattened portion of the screws, thereby preventing any accidental turning of the rods. Assemble the negative carrier securely by tightening the screw rings 459415 firmly onto the threaded ends of the rods (illus. 1).

When using larger film sizes even greater stability of the negative carrier is obtained by inserting the connecting rods into the plates in such a way that one screw thread will be on the left and the other on the right side of the negative carrier (Illus. 2).

The following table indicates the figures to be used on the spacer rods for various film formats:

1	2	3	4
10×15 cm	9×12 cm	—	6,5×9 cm
10×10 cm	—	—	—
4×5"	3 1/2×4 3/4"	3 1/4×4 1/4"	2 1/2×3 1/2"

B. Inserting sheet film or glass plates in the dark

When loading sheet films into the carrier it is advisable to use the loading guide 459416. The two upper cross bars of the frame have sharp edges while the lower one is rounded. This facilitates identifying the slots in the dark and lessens the danger of accidentally putting two films into one slot. It also prevents inserting film at an angle (Illus. 6).

PLATES



Illus. 5

FILM



Illus. 6

FILM



Illus. 7

The loading of glass plates is made easier by the protruding upper tips of the grooves which serve as loading guides (Illus. 5)

The loading guide frame is hooked into position by placing the top cross bar over the two projecting guide grooves and then pressing the bottom edge of the loading frame into the cut-out on the sides of the carrier plates (Illus. 7). This prevents the guide frame from slipping while working in the dark.

When loading it is preferable to insert the first film or plate into the slot closest to the handle. When using the film guide frame insert the first film into the top slot in the frame, the second sheet into the middle slot and the last sheet into the bottom slot. The film must rest firmly on the film stop plate of the lower spacer rod. Films should be inserted so the emulsion side faces forward and the backing faces the center of the carrier. This ensures that the emulsion will be pressed away from the grooves when the film retaining clip is positioned thus allowing the chemistry to reach all areas of the emulsion including the extreme edges.

When processing very valuable films it is advisable to insert only two films on each side of the carrier with no film in the center slots.

To remove the loading frame slightly raise the bottom edge of the frame and then lift it off.

When the loading frame guide has been removed slip the film retaining clip over the handle on the upper spacer rod and slide it down until it contacts the upper edge of the film. Make sure that the upper edges of the film are properly separated and that the clip holds its position firmly. Also check that the bottom edges of the film are properly separated on the lower spacer rod's stop plate (Illus. 8).

IMPORTANT: SEE LAST PAGE FOR ADDED INSTRUCTIONS.

Illus. 8

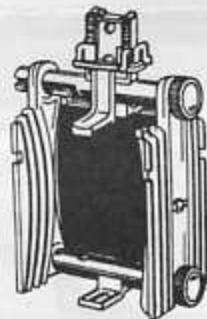

Now place the loaded carrier into the tank and press the lid firmly over the edge of the tank until it makes firm contact with the rim. Screw the light-tight hose connectors (459421) into the openings on the lid and in the tank body.

To remove the lid simply lift up on one corner.

C. Developing with the HP COMBI PLAN "T"

Loading the negative carrier with film or plates must be carried out in total darkness. All processing operations may be performed in daylight once the tank is closed.

If the first processing solution has not been poured into the tank before insertion of the negative carrier proceed as follows:

a. To fill the COMBI PLAN "T"

1. Put funnel 459425 on the screw-in connector 459421 on the lid.
2. Turn the nipple 1/2 turn counter-clockwise to open air path.
3. Close the screw-in nipple on the tank body with cap 459422.
4. Measure the required amount of solution as per the table below and pour the solution into the tank through the funnel.

9 × 12 cm	3 1/4 × 4 1/4"	4 × 5"
1000 ccm	1000 ccm	1050 ccm
35 oz	35 oz	36 oz

A shield is positioned under the opening in the lid prevents the solutions from splashing onto the negatives while the tank is being filled. The shield ensures that the solutions will rise evenly from the bottom of the tank which results in even development.

b. Processing method

1. Remove the funnel and cap the screw-in nipple.
2. Close the air path by firmly turning the screw-in nipple clockwise.
3. Firmly tap the closed tank several times on a hard surface to dislodge any air bubbles from the film's surface.

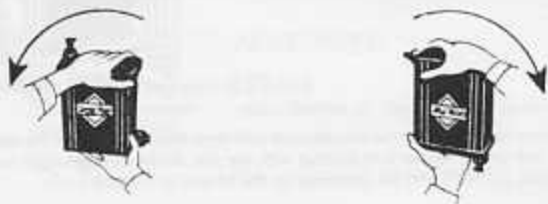

illus. 9

4. Inverse agitate the solutions by a smooth, not too abrupt tilting of the tank from side to side, and alternately to the left and right in an arc of approx. 180°. Please follow film manufacturers directions for frequency and length of agitation.

c. Draining the COMBI PLAN "T"

1. Remove the cap from the screw-in nipple on the lid.
2. Put funnel into the solution bottle.
3. Remove cap from the screw-in nipple on the tank's side and pour solution through the funnel and into the bottle.

illus. 10



4. Washing is easily accomplished as per illustration 10. A rubber hose runs from the faucet to the screw-in nipple on the side of the tank. The pressure of the water forced through the tank from the bottom to the top ensures a particularly thorough washing.

It is advisable to periodically reverse the negative carrier during the wash cycle to prevent any possible damage to the film during the wash.

d. Cleaning the tank and the negative carrier

After each developing session the negative carrier should be disassembled and each part cleaned with a brush in luke-warm to which a little detergent is added. The same procedure should be used to clean the tank and the lid. **NEVER USE HOT OR BOILING WATER. NEVER PLACE THE PARTS ON A STOVE, HOT PLATE OR NEAR A FIRE FOR DRYING.** It is important to note that film can easily and safely be loaded into a damp negative carrier when processing several loads of film.

D. Processing with a line of COMBI PLAN tanks

If there is a large amount of processing to be done it may be advisable to assemble a processing line. This can be easily and economically accomplished as shown below. Note that the number of tanks required will depend on the process used.

Please be sure to cover any open tanks to prevent oxidation. A piece of plastic food wrap laid over the open top of a tank is an inexpensive and effective way of preventing oxidation.

E. Proper use and care of Film Retaining Clip 459417

4 small ratchets on the clip engage 4 rack type bars on the outer edges of the handle on the upper spacer bar to securely lock the film retaining clip onto the handle.

TO DISENGAGE AND REMOVE THE CLIP FROM THE HANDLE GENTLY PRESS TOGETHER THE 2 BARS OF THE CLIP (ILLUS. 11) USING THE THUMB AND INDEX FINGERS OF BOTH HANDS AND LIFT OFF (ILLUS. 13 FRONTAL VIEW).

THE INHERENT SPRING ACTION OF THE PLASTIC MATERIAL USED FULLY MEETS THESE REQUIREMENTS. DO NOT ABUSE THE CLIP. NEVER SQUEEZE OR PULL APART THE CLIP BY FORCE (ILLUS. 12) AVOID EXCESSIVE WEAR BY NEVER ALLOWING THE RATCHETS OF THE CLIP TO RIDE AGAINST THE RACKS OF THE HANDLE. ALWAYS SLIP-ON OR REMOVE THE CLIP WITH THE RATCHETS RELEASED, I.E. WITH A GENTLE BUT FIRM PRESSURE ON THE 2 BARS OF THE CLIP. (ILLUS. 14).

Gently press these two bars

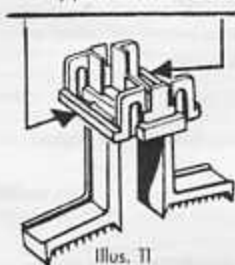

Illus. 11

Do not press arms



Illus. 12

Squeeze bars and lift

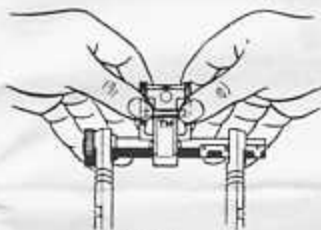

Illus. 13



Illus. 14

HP COMBI PLAN "T"
"the foolproof developing tank"

**THE PROFESSIONAL PROCESSING SYSTEM
THAT IS BEST SUITED TO YOUR NEEDS**

MADE IN SWEDEN