

EBONY

PROFESSIONAL VIEW CAMERAS



“Perfection is within your reach.”

EBONY SV45 series *

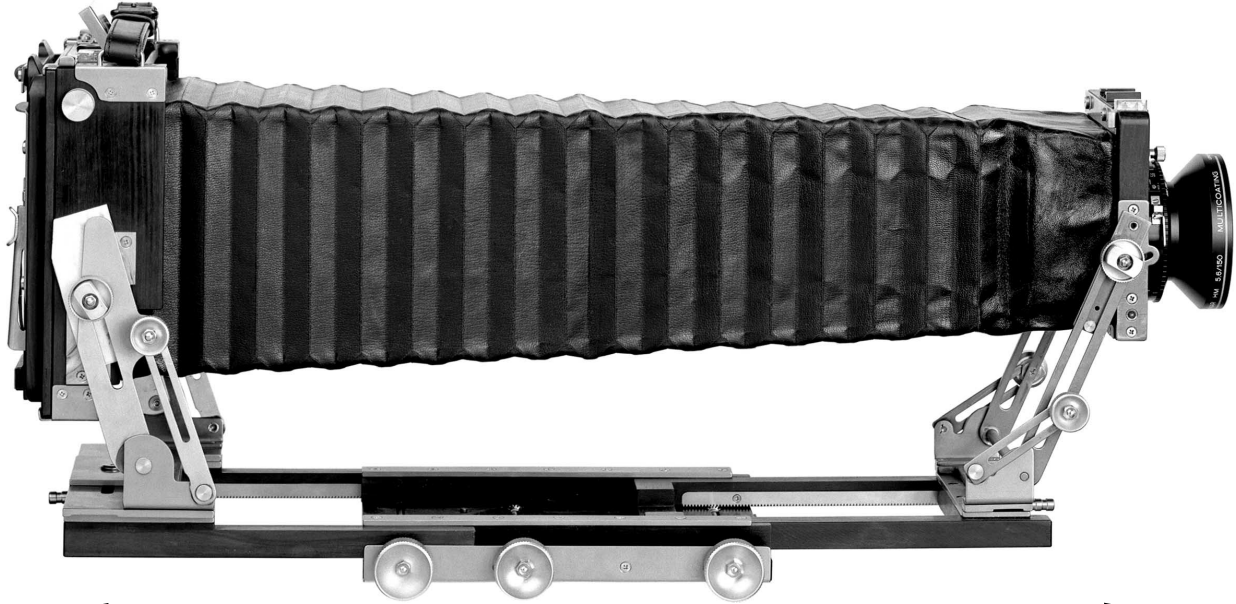

590mm maximum extension with tilts and rise



Wide-angle bellows may be used with 35-210mm lenses



Extremely compact

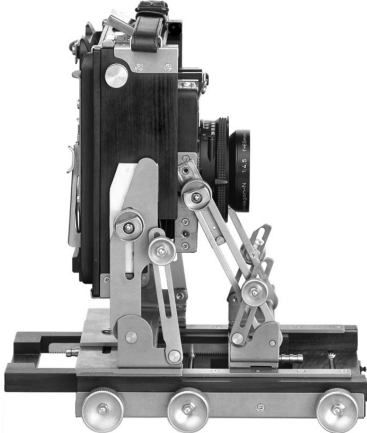

Wide-angle configuration with tilts and rise

Front Movements

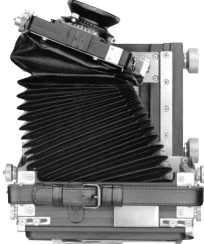
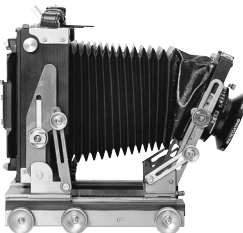
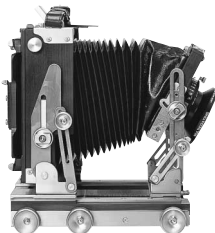
<p>Rise 42 mm, Fall 23 mm</p> 	<p>Shift 32 mm + 32 mm Swing 20° + 20°</p> 	<p>Base tilt forward 30°, backward 90°</p> 	<p>Center tilt 30° + 30°</p> 
---	--	---	--

Back Movements

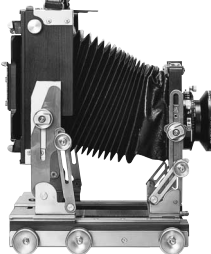
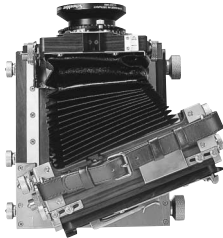
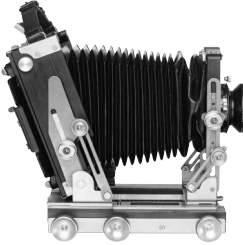
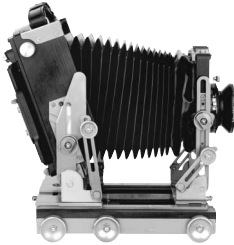
<p>Rise 45 mm</p> 	<p>Shift 50 mm + 50 mm Asymmetrical swing 20° + 20°</p> 	<p>Base tilt forward 90°, backward (bed drop) 30°</p> 	<p>Asymmetrical tilt 20° + 20°</p> 
---	---	--	--

* Model depicted: SV45U2

EBONY SV45 series

Ebony's legendary series of folding 4x5 cameras.

The SV45U2, SV45U and SV45TE are superbly crafted from quarter-sawn ebony heartwood, one of nature's hardest, strongest and most stable construction materials. This extremely dense and straight-grained wood is aged for over 20 years before it is cut, and finished with a premium grade oil to retain its unique natural lustre.

The SV45Ti is constructed with the same care and attention to detail from 15-year-old quarter-sawn mahogany heartwood, and finished with exquisite Lacquer Japan ('urushi').

As with all Ebony cameras, the metal parts of the SV45 series are made of solid titanium - harder, stronger and lighter than stainless steel. The uniquely thin and supple yet durable calfskin bellows are hand-made to Ebony's specifications. The hand-strap is made of genuine cordovan leather. All parts are made to unequalled standards of precision and meticulously assembled by hand. Every camera is then rigorously checked and tested by Ebony's team of craftsmen to ensure total accuracy and reliability.

The Ebony SV45 series are cameras without compromise - in materials, craftsmanship or range of abilities.

- Absolutely rigid construction: no vibration or sway, even at maximum extension. Complete stability is assured.
- The movements, precision and rigidity of a view camera with the portability of a field camera
- Base and center tilts at both front and back (Asymmetrical tilts and swings replace center tilts and swings on back standard of SV45U and SV45U2 allowing perfect focus to be maintained during adjustments.)
- Huge triple-draw bellows extension enabling use of 35mm-800mm lenses. (Universal bellows, allowing greater range of movements with wide-angle lenses, replace standard bellows on SV45U2 and SV45U. Interchangeable wide-angle bellows also available as optional accessory for all SV cameras.)
- 35/38mm lens may be used with recessed lensboard
- Foldable, with 30° bed drop
- Compatible with Linhof-type 4x5 lensboards
- **Accepts both 4x5 International Standard and 6x9 Graphic Standard roll film holders (Horseman, Mamiya RB67 etc.): format reducing adapter required for 6x9 roll film or instant film holders.**

SPECIFICATIONS

CAMERA TYPE		Folding view camera	
FORMAT		International Standard 4x5 inch. Accepts all International Standard sheet film holders: Polaroid 405, 545, 550, Fuji Instant MS45, PA45, and all Graphic Standard roll film holders.	
CONSTRUCTION MATERIALS		Ebony (SV45U2, SV45U, SV45TE) or mahogany (SV45Ti) and titanium	
FOCUSING SYSTEM		Triple-draw rack and pinion (front and back focusing)	
LENSBOARD		4x5 Linhof-type	
CAMERA BACK		Interchangeable vertical/horizontal International Standard	
FOCUSING SCREEN		Fresnel lens with 10mm grid, protective glass	
MOVEMENTS (levers lock swings and shifts, knobs lock all other movements)	FRONT	Rise 42mm, Fall 23mm, Shift 32mm+32mm, Swing 20°+20°, Base tilt forward 30°, backward 90°, Center tilt 30° + 30°	
	BACK	SV45U2	Rise 45mm, Shift 50mm+50mm, Asymmetrical Swing 20°+20°, Base tilt forward 90°, backward (bed drop) 30°, Asymmetrical tilt 20°+20°
		SV45U	Rise 45mm, Asymmetrical swing 20°+20°, Base tilt forward 90°, backward (bed drop) 30°, Asymmetrical tilt 20°+20°
		SV45TE/Ti	Rise 45mm, Shift 50mm+50mm, Swing 20°+20°, Base tilt forward 90°, backward (bed drop) 30°, Center tilt 20°+20°
BED	Drop 30°		
ZERO ("NULL") POSITION RESET		Front swings and asymmetrical/center tilts: zero detents Back rise: lowest position Front rise/fall: zero position alignment points Shifts: zero position on scale Base tilts: zero position notches	
MIN/MAX BELLOWS EXTENSION		SV45U2	85mm (55mm with tilts and rise) - 510mm (590mm with tilts and rise)
		SV45U	85mm (55mm with tilts and rise) - 445mm (530mm with tilts and rise)
		SV45TE/Ti	85mm (55mm with tilts and rise) - 445mm (530mm with tilts and rise)
USABLE LENSES		35mm* - 800mm telephoto *35mm - 47mm lenses (except 47XL) require recessed lensboard	
SPIRIT LEVEL	FRONT	One-way	
	BACK	Two-way with mirror	
WEIGHT / DIMENSIONS		SV45U2	3.15 kg / 20.5 (h) x 20.5* (w) x 9.5 (l) cm
		SV45U	2.7 kg / 17.5 (h) x 17.5* (w) x 9.5 (l) cm
		SV45TE	2.7 kg / 17.5 (h) x 20.5* (w) x 9.5 (l) cm
		SV45Ti	2.1 kg / 17.5 (h) x 20.5* (w) x 9.5 (l) cm * including knobs

— EBONY ACCESSORIES —

(BELLOWS INCLUDED WITH EVERY CAMERA, AND FRESNEL LENS WITH ALL 4X5 AND 6X9 CAMERAS)

Custom-built cameras also available

Ebony make a wide range of top-quality accessories built to the same professional standards as our cameras, enabling the discerning photographer to create a complete medium-format and large-format camera system.

ACCESSORY NAME	APPLICABLE CAMERA(S)
Interchangeable wide-angle bellows	All SV cameras, 45SU
Interchangeable standard bellows (4x5)	SV45TE/Ti
Interchangeable universal bellows (4x5)	SV45U2, SV45U, SV45TE/Ti, 45SU
Fresnel lens (with grid)	All 4x5/6x9 backs
Wide-angle Fresnel lens	All 4x5/6x9 backs
Protective glass	All 4x5/6x9 backs
Instant film holder GP	23S, SW23
Instant film holder for format reducing adapter	All 4x5 backs with format reducing adapters
Format reducing adapter 4x5->6x9 (mahogany)	All 4x5 backs
Format reducing adapter 4x5->6x9 (ebony)	All 4x5 backs
Reducing back 8x10->5x7	All 8x10 backs
Reducing back 8x10->4x5	All 8x10 backs
Reducing back 5x7->4x5	All 5x7 backs
Extension back 452 (90mm, plus 10° tilt)	45SU, 45S, SW45
Extension back 692 (90mm, plus 10° tilt)	23S, SW23
Extension tube kits (17mm, 35mm)	All camera lenses with Linhof-type lensboard
Lens box	All camera lenses with Linhof-type lensboard
Lens shade clip	All cameras
Bellows-type focusing hood	All 4x5 cameras
Regular focusing cloth	All cameras
All-weather focusing cloth (1.5 m ² , requires lens shade clip)	All cameras
Lensboards (Linhof-type, aluminium with ebony) Copal #0, #1	All 4x5/6x9 cameras



Format reducing adapter 4x5->6x9

The format reducing adapter may be used with all International Standard 4x5 backs. (Flange back is increased by 6mm.) 6x9 roll film holders may be removed without dismounting the focusing screen.

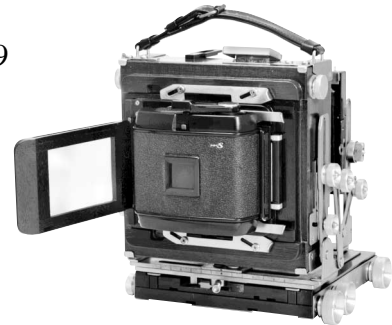

All-weather focusing cloth (requires lens shade clip)

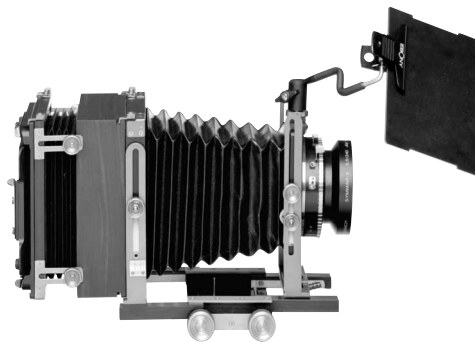

SW45 with extension back 452 and lens shade clip



17mm and 35mm extension tubes

EBONY CO., LTD.

Shin Oyama Building, 1st Fl.,
38-12 Oyama Kanai-cho,
Itabashi-ku, Tokyo 173, Japan
Tel: +81-3-3972-3170
Fax: +81-3-5995-3738

E-mail hiromi@ebonycamera.com
Web Site www.ebonycamera.com